

TECHNICAL DATA

RATED FLOW [M3/H]	15m3/hr
MAX FLOW	23m3/hr
MAX HEAD	143.6M
OPTIMUM OPERATING RANGE	9m3/hr @ 137.1m 47.1% eff 18.8m3/hr @ 120.5m 65.9% eff
WORKING AIR TEMP	0°C - 40°C
LIQUID TEMPERATURE	-15°C - 120°C
HIGHEST EFFICIENCY	68.7%
MAXIMUM PUMP PRESSURE	31 bar
NET WEIGHT (KG)	148kg

RATED VOLTAGE/CURRENT	Three phase 415V +10% - 6%
RATED CURRENT	19.84 amps
POWER (KW)	11kW 2 pole
MOTOR IP RATING	IP55
MOTOR INSULATION	Class F
MOTOR EFFICIENCY STD	I.E.3
MOTOR EFFICIENCY	91.2%
COS Ø	0.89
MECHANICAL SEAL	AS-L-16
OUTLET DIN FLANGE	DN50

DIMENSIONS

HEIGHT A	523
DIAMETER B	311
RADIUS C	235

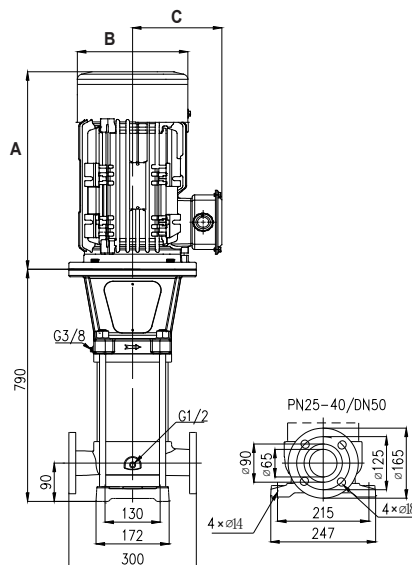

CURVE

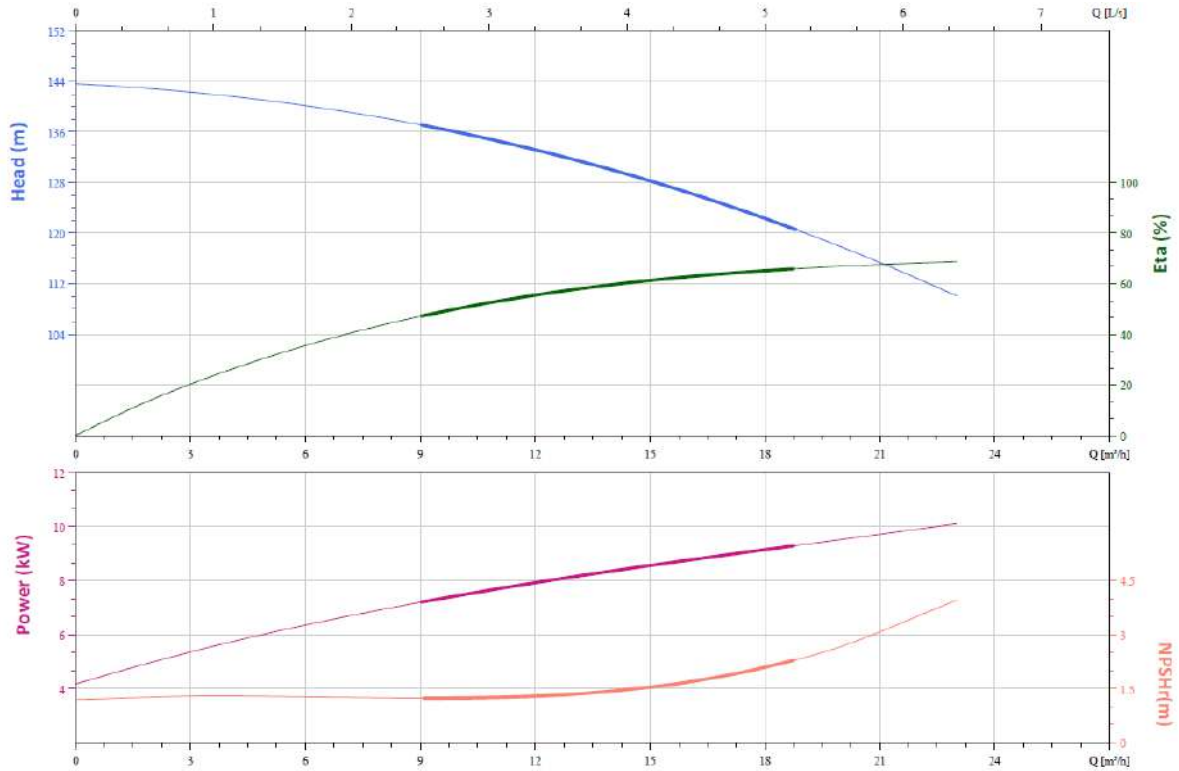

VFD CURVE

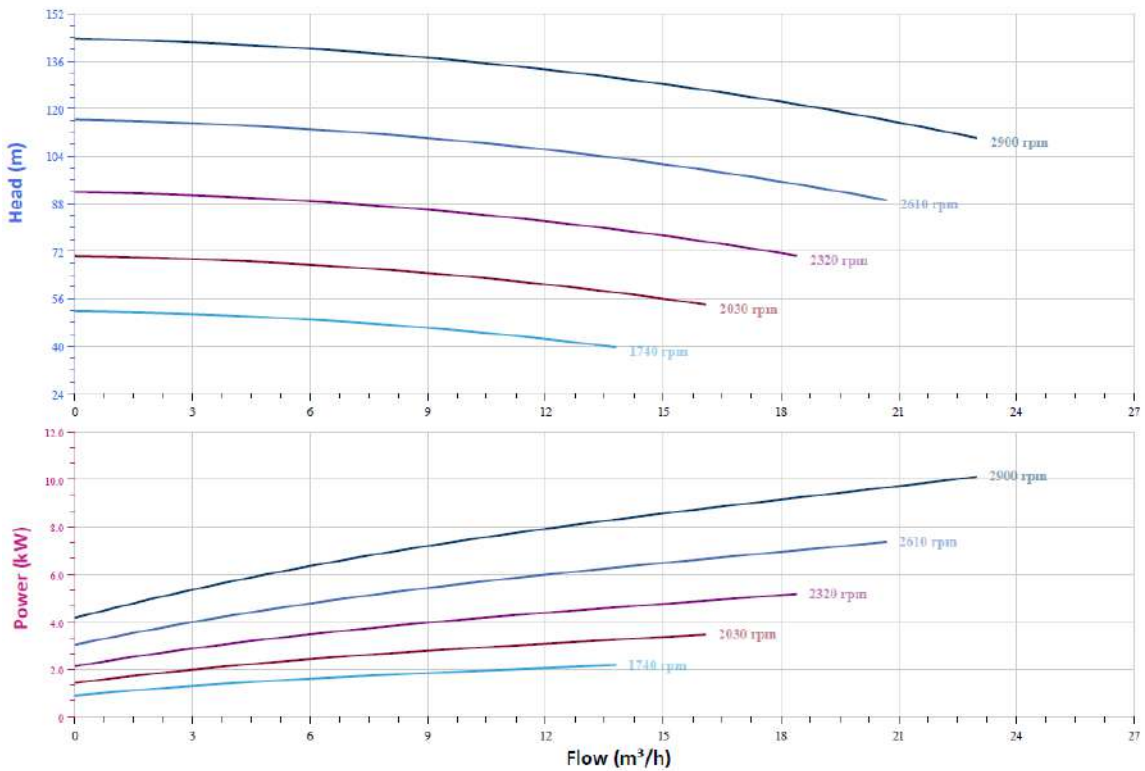

DUAL PUMP CURVE

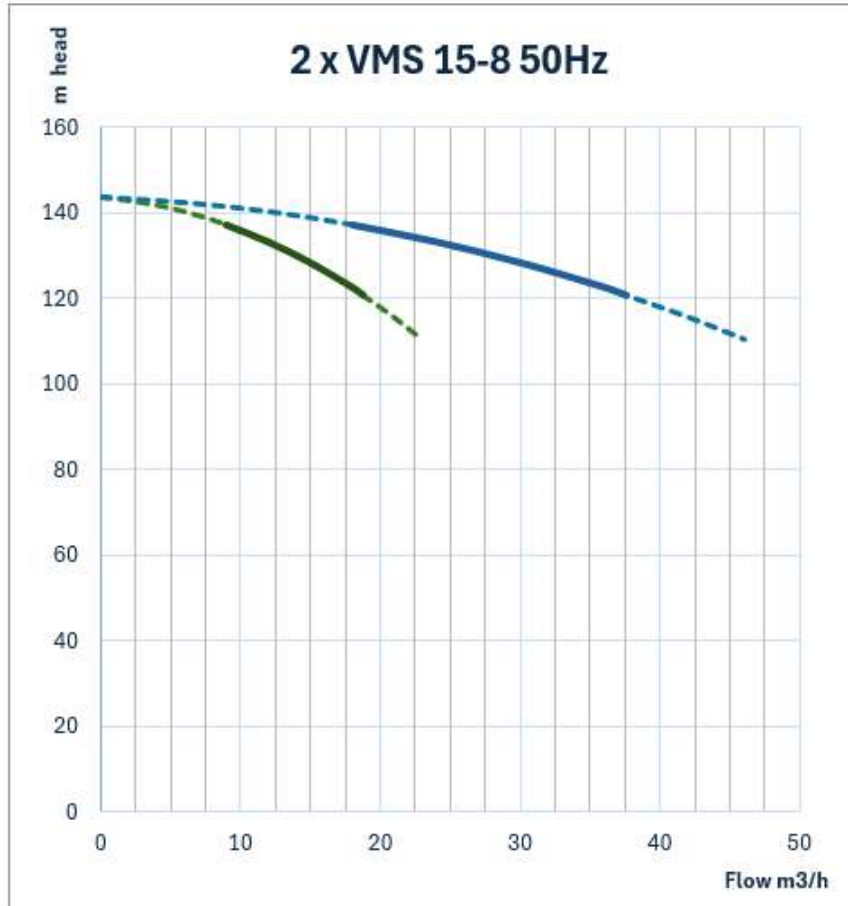

CUTAWAY AND MATERIALS

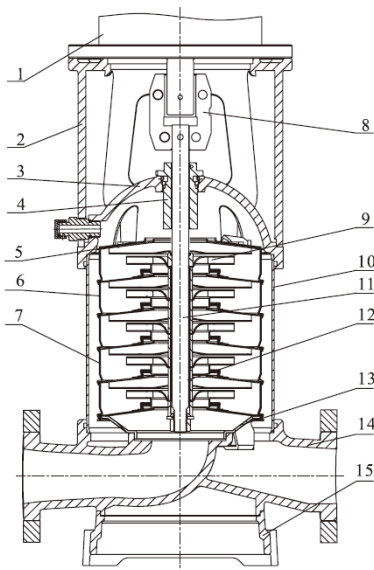

1	Motor	/
2	Bracket	Ductile Cast Iron
3	Seal Base	Stainless / Ductile Cast Iron
4	Mechanical Seal	AS-L-16
5	Top Diffuser	Stainless Steel
6	Diffuser	Stainless Steel
7	Support Diffuser	Stainless Steel
8	Coupling	Stainless Steel
9	Impeller	Stainless Steel
10	Cylinder	Stainless Steel
11	Shaft	Stainless Steel
12	Intermediate Bearing	SIC / WC
13	Inducer	Stainless Steel
14	Inlet/Outlet Chamber	Stainless Steel / Ductile Cast Iron
15	Base	Ductile Cast Iron

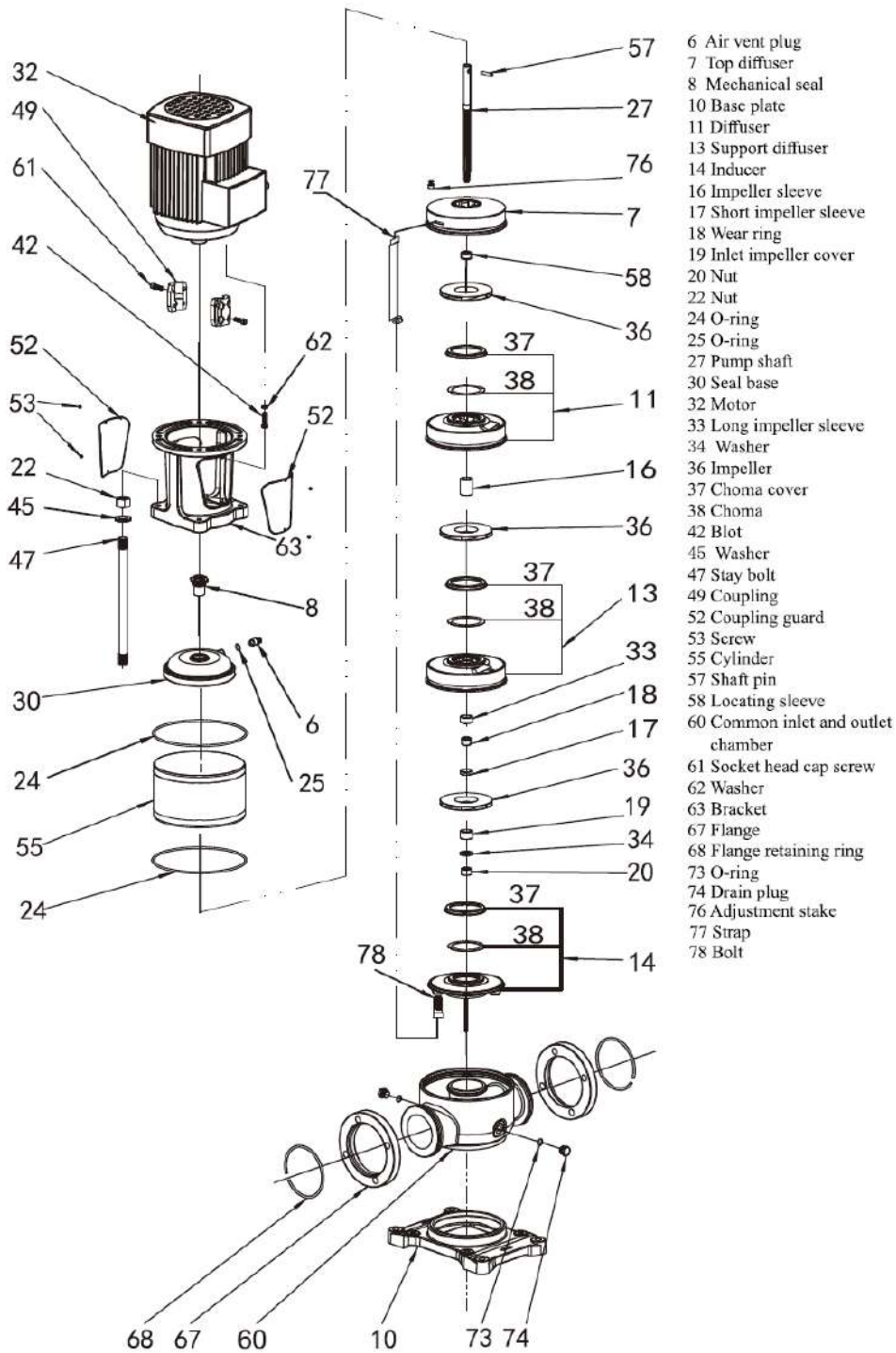

WARRANTY / CERTIFICATIONS

